

CR

SERIES



### Description

The Generant Series CR Cryogenic Regulator provides high flow during Cryogenic Vessel Pressure Build function and increased sensitivity to downstream pressure changes as a function of our pre-formed all metallic diaphragm and optimized spring design. The unique diaphragm is unlike anything on the market today and results in less decrease in Cryogenic vessel pressure and faster recovery during periods of higher demand, thus decreasing the potential for flooding the pressure build coil. The unit features a Monel Strainer/Filter to aid in reducing contaminant related failures. All Series CR Cryogenic Regulators are 100% Factory Tested and are supplied factory pre-set.

### Features

- Designed for High Flow Liquid Service
- Can be installed Upstream or Downstream of the Vaporizer
- Unique Pre-Formed Multiple Stacked Phosphorous Bronze Diaphragms
- Can be Supplied Factory Preset
- Hex Head Adjustment Screw with Locknut
- Monel Inlet Strainer/Filter
- Cleaned and Packaged for Oxygen Service

### Materials of Construction

- Forged Brass Body and Chamber, ASTM 377
- Brass Bar Stock Components, ASTM B16
- Phosphorous Bronze Diaphragms, ASTM B103
- PTFE Valve, Diaphragm and Bottom Plug Seal, ASTM D1710
- PCTFE Valve Stem Bearing, ASTM D1430
- 17-7PH Stainless Steel Adjustment and Valve Spring, ASTM A313
- Stainless Steel Adjustment Screw and Locknut, ASTM A276
- Monel Inlet Strainer/Filter

# CRYOGENIC/PRESSURE BUILD REGULATOR

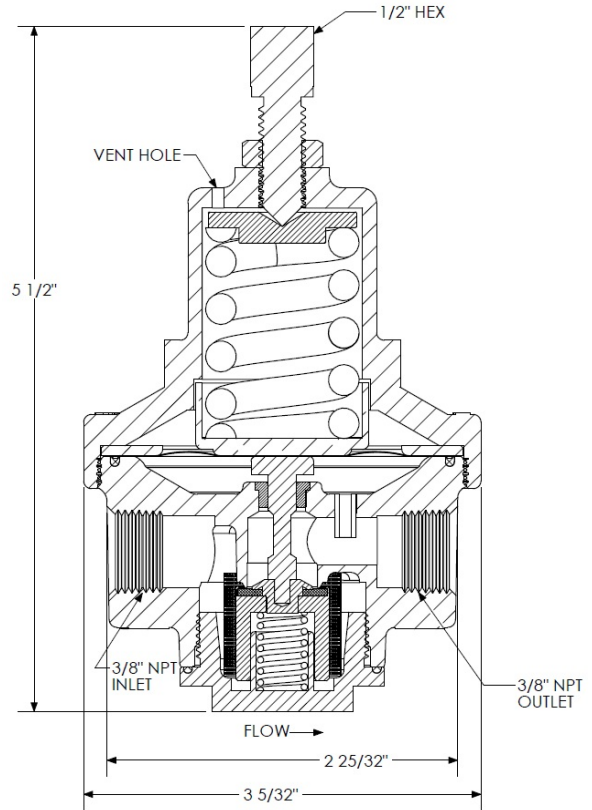
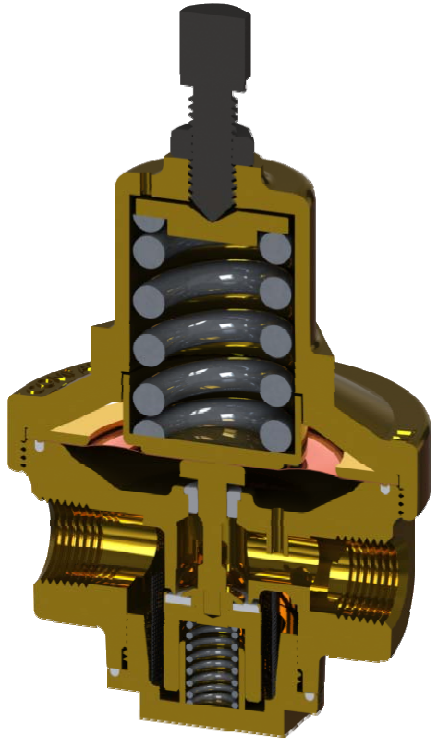

## Technical Data

Maximum Inlet Pressure: 400 Psi (28 Bar)  
 Outlet Pressure Range: 0 to 235 Psi (0 to 16 Bar)  
 Temperature Range: -320° to 225° F (78° to 380° K)

## Flow Capacity

Flow Capacity is system dependent. For accurate flow capacity data, consult Generant with your specific system characteristics for more information.

## How To Order

2CR-375-C

SERIES  
2CR-2 Port Cryogenic/Pressure Build Regulator

OUTLET PRESSURE CODE

CODE	RANGE (PSI)	FACTORY SETTING (PSI)	PSI/TURN (APPROX)
A	0 - 35	20	5
B	25 - 135	75	17
C	100 - 235	150	55

PORT SIZE  
 375-3/8" FNPT  
 500-1/2" FNPT  
 4BSPT-1/2" BSPT

*Note: Regulators are supplied pre-set to factory setting shown above. When adjusting regulator set pressure up (CW) or down (CCW), approximate PSI/TURN can be used as a reference.*

## Repair Kits

Includes: Valve Assembly, Bottom Plug O-Ring, Valve Spring, Monel Strainer, Valve Stem, Preformed Phosphorous Bronze Diaphragms (2) and Diaphragm O-Ring.

Specify: CR-RK-500

*Note: Repair Kit fits all port sizes.*

## Replacement Spring Kits

Includes: Adjustment Screw and Spring

Specify: CR-SK-500-A, 0-35 PSI Range  
 CR-SK-500-B, 25-135 PSI Range  
 CR-SK-500-C, 100-235 PSI Range

*Note: Adjustment Screws are sized according to Springs. Spring Code is engraved on the Adjustment Screw (A, B, C).*

For additional configurations consult factory.

PROPER COMPONENT SELECTION – When specifying a component, the total system design must be considered to ensure safe and trouble-free performance. Intended component function, materials compatibility, pressure ratings, installation, environment and maintenance are the responsibility of the system designer.



[www.generant.com](http://www.generant.com)

1865 Route 23 South PO Box 768 Butler, New Jersey 07405 973.838.6500 Fax 973.838.4888